



How (and why not) to Amplify PMT Signals

'I have to detect a light signal in the ns range. I use a PMT, but the noise is too high so that I can't see the signal. Which amplifier can I use to improve the signal-to-noise ratio?' The answer to this frequently asked question is usually **'none'**, and the general recommendation for using an amplifier for PMT signals is **'don't'**.

This consideration explains the peculiarities of PMT signals and gives hints to handle these signals.

The PMT

A conventional PMT (Photomultiplier) is a vacuum tube which contains a photocathode, a number of dynodes (amplifying stages) and an anode which delivers the output signal.

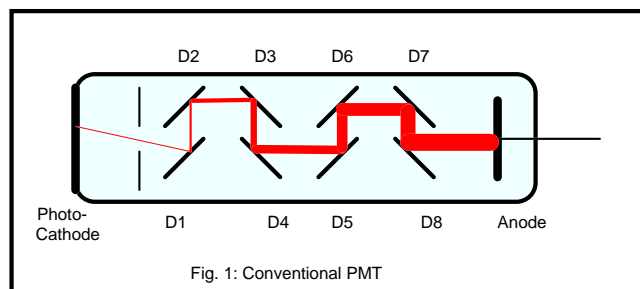

By the operating voltage an electrical field is built up that accelerates the electrons from the cathode to the first dynode D1, from D1 to D2 and to the next dynodes, and from D8 to the anode. When a photoelectron emitted by the photocathode hits D1 it releases several secondary electrons. The same happens for the electrons emitted by D1 when they hit D2. The overall gain can reach values of 10^6 to 10^8 . The secondary emission at the dynodes is very fast, therefore the electrons resulting from one photoelectron arrive at the anode within some ns. Due to the high gain and the short response a single photoelectron yields a easily detectable current pulse at the anode.

The operating voltage of a PMT is in the order of 800V to some kV. The gain of the PMT strongly depends on this voltage. Therefore, the gain can be conveniently controlled by changing the operating voltage.

MCP (Micro Channel Plate) PMTs achieve the same effect by a plate with millions of microchannels. The channel walls have a conductive coating. When a high voltage is applied across the plate the channel walls act as a secondary emission target, and an input photon is multiplied by a factor 10^5 to 10^6 .

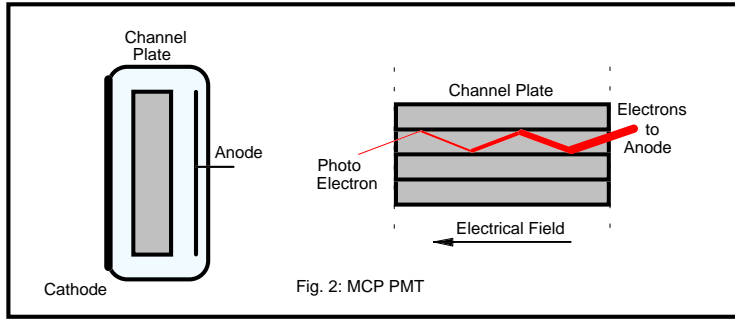

Fig. 2: MCP PMT

Due to their compact design, MCP-PMTs are extremely fast.

The PMT Signal

The output pulse for a single photoelectron is called the ‘Single Electron Response’ or SER of the PMT. Some typical SER shapes are shown in the figure below.

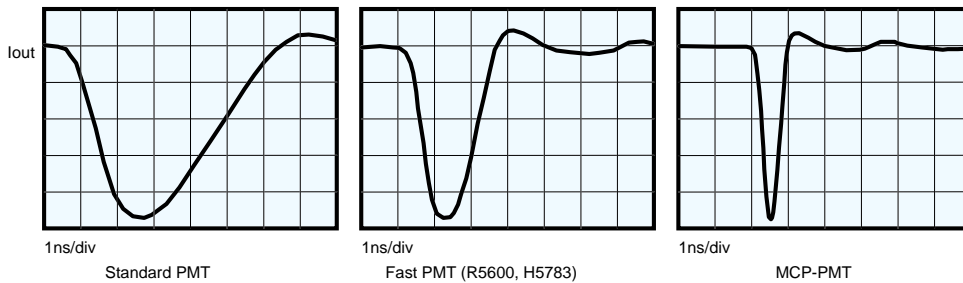

Fig. 3: Single Electron Response of Different PMTs

The peak current of the SER is approximately*

$$I_{ser} = \frac{G \cdot e}{FWHM}$$

(G = PMT Gain, $e=1.6 \cdot 10^{-19}$ As, FWHM= SER pulse width, full width at half maximum)

Due to the random nature of the PMT gain, I_{ser} is not stable but varies from pulse to pulse. The distribution of I_{ser} can be very broad, up to 1:5 to 1:10. With G being the average gain, the formula delivers the average I_{ser} which is sufficient for the following considerations.

The table below shows some typical values. I_{ser} is the average SER peak current and V_{ser} the average SER peak voltage when the output is terminated with 50 Ω. For comparison, I_{max} is the maximum useful output pulse current of the PMT.

PMT	PMT Gain	FWHM	I_{ser}	V_{out} (50 Ω)	I_{max} (cont)	I_{max} (pulse)
Standard	10^7	5 ns	0.32 mA	16 mV	100uA	50mA
Fast PMT	10^7	1.5 ns	1 mA	50 mV	100uA	100mA
MCP PMT	10^6	0.36 ns	0.5mA	25 mV	0.1uA	10mA

Table 1: Typical PMT parameters

The conclusions from the table above are:

1. The output voltage for a single detected photon is in the order of some 10mV at 50 Ω. This is much more than the noise of any reasonable electronic recording device. Thus, the PMT easily ‘sees’ the individual photons of the light signal. Further amplification cannot increase the number of signal photons and therefore does not improve the SNR.

2. The peak current for a single photon, I_{ser} , is greater than the maximum continuous output current, $I_{max(cont)}$. Therefore, a continuous light signal does not produce a continuous current at the PMT output but a train of random SER pulses.

3. The peak current for a single photon, I_{ser} , is only 1/20 to 1/100 of the maximum output pulse current, $I_{max(pulse)}$. Thus, even for light pulses no more than 20 to 100 photons can be detected at the same moment. This limits the SNR of the unprocessed PMT signal to less than 10. Actually the SNR is even worse because of the random nature of the PMT gain. Any additional amplifier can only decrease the ratio I_{max} / I_{ser} and therefore decrease the SNR.

The typical appearance of the PMT signal for the different cases is shown in the figure below.

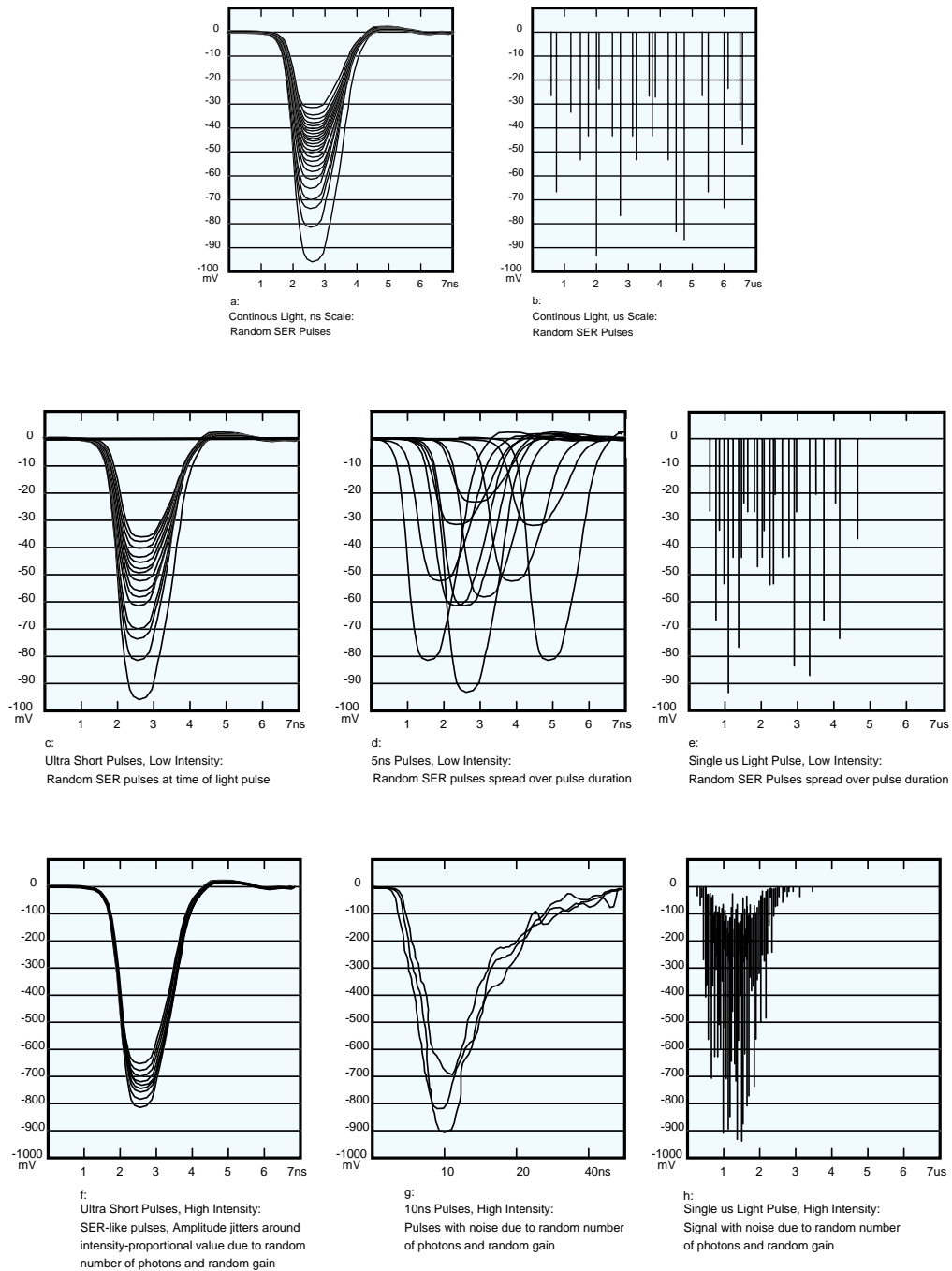

Fig. 4: PMT Signals for different Light Signal

Why NOT to use an Amplifier

Obviously, any additional amplification of the signals shown in fig. 4 does not improve the SNR. The SNR is limited by the number of signal photons which cannot be increased by the amplifier. Actually, an amplifier can only **decrease the useful dynamic range**, because it increases the signal for a single photon while setting additional constraints to the maximum signal level. The situation is shown in the figure below.

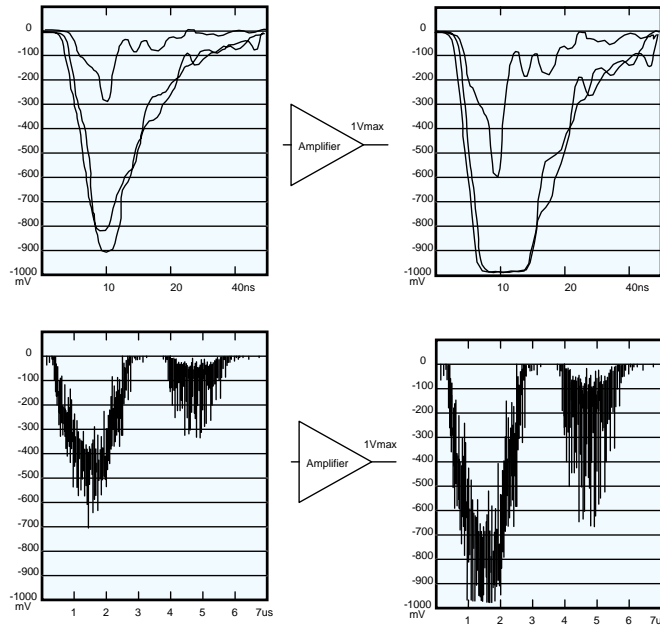

Fig. 5: Effect of an amplifier on a fast PMT signal

The amplifier has a gain of 2, but saturates for input signals above 500mV. Therefore, not the full output signal range of the PMT can be used. The bigger signals with their better SNR are distorted, while the SNR of the smaller signals remains unchanged. For longer signals (lower example) it can happen that only the peaks are clipped. Although this is often not noticed, it makes the signal useless for further processing.

When to use an Amplifier

Low Bandwidth Recording

When a PMT is used as a linear detector its pulse response is given by the SER. Therefore, PMTs are very fast devices. In some applications the high speed is not required, and the signal is recorded with a reduced time resolution. This can be achieved by a passive low pass filter, by a slow amplifier or simply by terminating the PMT output with a resistor much higher than 50 Ω . The slow recording device can be seen as a low pass filter which smoothens the SER pulses.

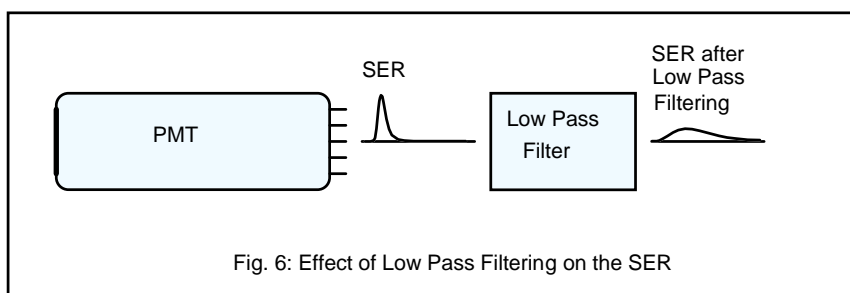

Fig. 6: Effect of Low Pass Filtering on the SER

The virtual peak current of the SER after the low pass filter is approximately

$$I_{serf} = \frac{G \cdot e}{T_{fil}} \quad \text{or} \quad I_{serf} = I_{ser} \frac{FWHM}{T_{fil}}$$

(G = PMT Gain, $e=1.6 \cdot 10^{-19}$ As, T_{fil} = Filter Rise Time, FWHM= SER pulse width, full width at half maximum)

The curves below show the virtual SER peak current and the SER peak voltage for a standard PMT and for different termination resistors.

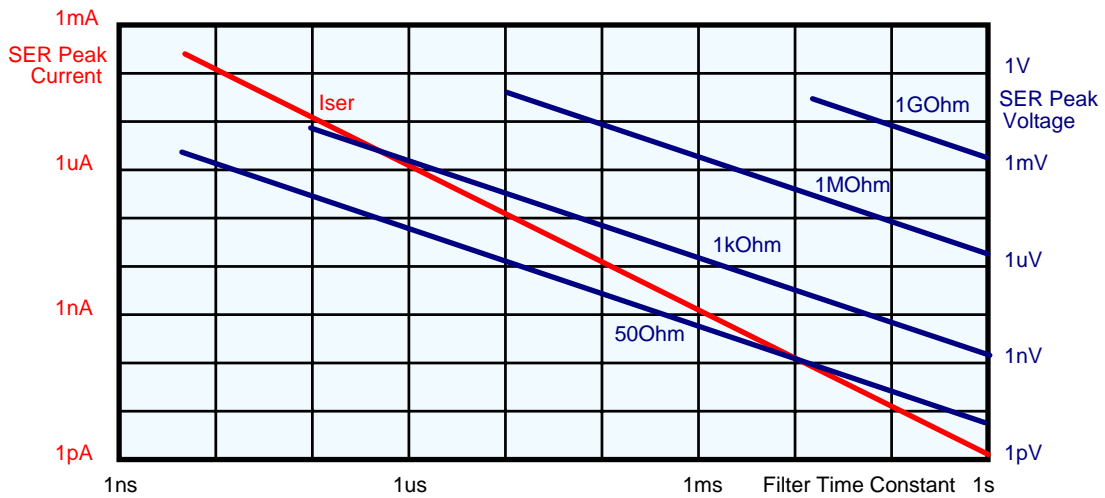
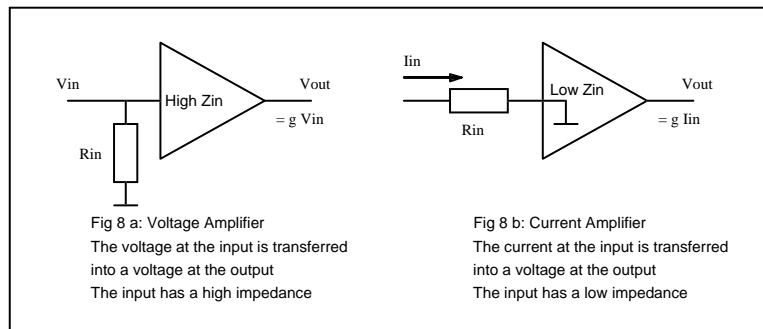

Fig. 7: Virtual SER peak current and SER peak voltage after low pass filtering

Fig. 7 shows that the virtual SER peak current drops to very low values for longer low pass filter times. Additional amplification can be required now. However, for slow measurements the loss of signal amplitude can be compensated by increasing the termination resistor which makes a high amplifier gain unnecessary.

Two basically different amplifier principles are available - the normal ‘Voltage’ amplifier and the ‘Current’ or ‘Transimpedance’ amplifier.



A Voltage Amplifier (fig. 8a) transfers a voltage at the input into a higher voltage at the output. The input of the amplifier represents a high impedance. The output current of the PMT is converted into a voltage at the input matching resistor R_{in} . This voltage appears with the specified gain at the amplifier output.

A Current Amplifier (fig. 8b) transfers a current at the input into a voltage at the output. Thus the gain of a current amplifier is given in V/A. The input of a current amplifier has a low

impedance. Ideally, the input should represent a short circuit. Practically an input matching resistor R_{in} is added (typically $50\ \Omega$) to maintain stability and to avoid reflections at the input cable. Current amplifiers are used to get fast signals from detectors which represent a current source with a high parallel capacitance. In the present case there is neither a high detector capacitance nor a requirement for high speed. Thus, a current amplifier is not the right choice to reduce the bandwidth of a PMT signal. There would be no reasonable and predictable bandwidth reduction, and the strong SER pulses could drive the amplifier into saturation without producing an equivalent output signal. If you really need a fast amplifier for a PMT signal, you should better use a GHz wideband amplifier in $50\ \Omega$ technique (see 'Photon Counting').

High Light Intensities

There are applications where the light intensity is so high that it would saturate the PMT operated at its normal gain. To get an optimum SNR from the PMT for these signals, it is better to reduce the PMT gain than to attenuate the light. However, if the PMT operating voltage is decreased by decreasing the operating voltage, also the speed and the useful output current range of the PMT decreases. To match the decreased signal range to the input range of a recording device a moderate amplification can be reasonable. However, this situation is unlikely because a PMT normally delivers enough output current even if its gain is reduced by some orders of magnitude. If the gain has to be reduced to extremely low values you should consider to use another detector - an avalanche photodiode or even a PIN photodiode.

Photon Counting

Signals as shown in fig. 4b, 4d and 4e are not effectively captured by analog data acquisition methods. They are better recorded by counting the individual SER pulses. This 'Photon Counting' method has some striking benefits:

- The amplitude jitter of the SER pulses does not appear in the result.
- The dynamic range of the measurement is limited by the photon statistics only.
- Low frequency pickup and other spurious signals can be suppressed by a discriminator.
- The gain instability of the PMT has little effect on the result.
- The time resolution is limited by the transit time spread of the SER pulses rather than by their width. This fact is exploited for 'Time-Correlated Single Photon Counting' to achieve a resolution down to 25ps with MCP PMTs.

Therefore, you should consider to use photon counting for light intensities that deliver well separated single photon pulses.

The discriminators at the input of a photon counter work best at a peak amplitude of some 100mV. Therefore, an amplifier is useful if the SER amplitude is less than 50 mV.

For photon counting with MCP PMTs an amplifier should always be used. Due to degradation of the microchannels by sputtering, these devices have a limited lifetime. Using an amplifier enables the MCP to be operated at reduced gain and reduced output current so that the lifetime is extended.

For photon counting the amplifier gain can be so high that the biggest SER pulses just fit into the amplifier output and the discriminator input voltage range. The amplifier should have sufficient bandwidth not to broaden the SER pulse of the PMT. This requires some 100MHz for standard PMTs and at least 1 GHz for MCPs. The input and output impedance should be

50 Ω for correct cable termination. Such amplifiers are known as 'GHz wideband amplifiers in 50 Ω technique and are available with a gain of up to 100 and a bandwidth of some GHz.